

BRAVO ROTATING CUTTER

A Tough, 2-Function Manipulator for Inspection Class Vehicles

The Bravo Rotating Cutter is comprised of the Bravo 2-function manipulator (RB-2130) with cutter end-effector attached (RB-1042).

- **DEXTEROUS**
2-Function (or custom fit)
Highly Modular & Configurable
- **RUGGED**
450m Depth Rating
2kN Axial Load
- **SMART**
In-Built Kinematics
Master Arm Controlled



ROV & UGV Proven

NEW MK2 FEATURES

- Slip-rings in all inlines
- Increased 450m depth rating (600m rated in the future)
- High strength linear (approx. up to 10kN)
- Higher joint speed
- Increased reliability & easier maintenance

FEATURES

- Ready-built and designed for industry leading inspection-class vehicles
- All-Electric, Zero Oil
- End effectors: grabbers, probe handlers, cutters (or BYO)
- Advanced software interface with 3D visualisation
- Adjustable grab force - pick up a sea urchin or cut a cable
- Quick to integrate



STRONG GRIP, CLEAN CUT

The Bravo Rotating Cutter is essential for intervention missions requiring force and precision. This configuration combines the manipulators powerful linear and continuous rotatory actuator, with the end effectors ability to sever softline, copper and electrical cable up to 25mm diameter, resulting in a powerful tool for inspection-class ROVs.

- **ELECTRICAL**
Voltage 24-48V
Nominal Power 60W
COMS RS232/RS485/Ethernet
- **ENVIRONMENTAL**
Depth 450MSW
Temp 0°C to 40°C
Material AL7075 T6
- **MECHANICAL**
Weight (Air) 2800g
Weight (Water) 1600g

Master Arm Controller Enabled
Note: Master Arm not included



Mission Specific End-Effectors | Interchange With Ease



RB-1025



RB-1055



RB-1041



RB-1043



RB-1044 SS



RB-1042



RB-1034

SPECIFICATIONS

Wrist Torque	20Nm
Axial Load Rating	2kN
Rotate Speed	45°/s nominal
Rotate Accuracy	0.1°
Linear Force	10kN
Jaw Clamp Force	80kg (800N)
Outer Diameter	81.6mm
Connector cable	13 Pin Ethernet Subcon (DBH13M)
Control Options	Space Mouse, Software GUI, Topside Master Arm
Control Modes	Position, Velocity

High Mobility & Compact

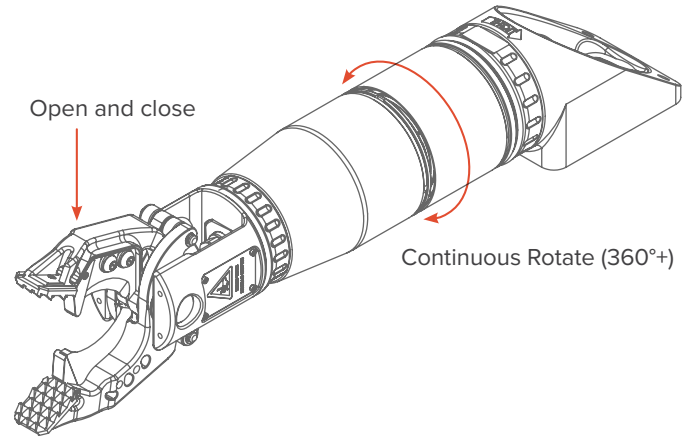

Integration Made Easy

Integrate Reach Bravo manipulators with our mounting unit, designed for simple installation on industry leading vehicles. A screw collar system lets you mount and unmount in seconds.

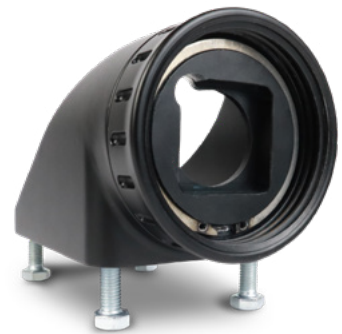
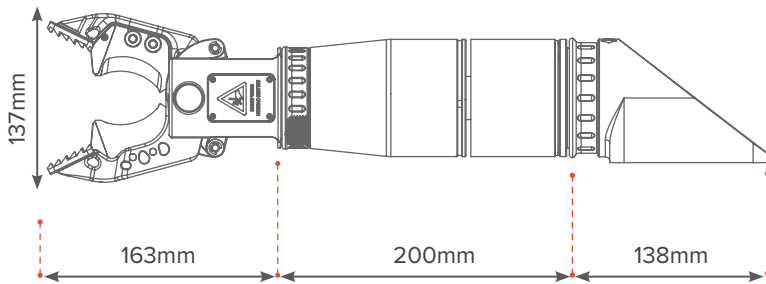

Note: Mount not included

A Revolution for Subsea Inspection & Intervention



Responsive
Integration Support



Responsive
Remote Support



12 Month
Warranty



1000+ Hours
Logged



Extended Warranty,
Spares Packages &
Service Plans Available